

Modular Cleanroom FRP Doors

Single Swing. Seamless Molded Fiberglass
Non Fire Rated, Manual or Automatic



LEADING EDGE TECHNOLOGY FOR SUPERIOR HYGIENE PERFORMANCE

Dortek's hygienic door systems are manufactured using cutting edge technology and a revolutionary closed mould process. This creates a strong, uniform product with no seams or joins on the door surface and no voids, holes or crevices within for bacteria to harbor.

We are market specialists; with over 50 years' experience in providing high performance door solutions to the world's leading pharmaceutical and healthcare companies.

We understand the unique and stringent requirements of high hygiene environments. We understand air flows, work flows, contaminants and local regulations. We know what works and what doesn't. Our product portfolio offers a comprehensive single source for all doors, frames, hardware and automations on a project.

Dortek is recognised throughout the markets we serve for its commitment to innovation, quality and customer care. Our clients trust our specialist expertise to find the right solution for every project and every door and to deliver that solution on time and to budget.

EXCEPTIONALLY CLEAN

Fully sealed seamless surface for a smooth attractive finish which is easy to keep clean. Free from organic materials, ledges and gaps to eliminate breeding grounds for bacteria.

INTELLIGENT DESIGN

Proven to maximise efficiency, safety and hygiene in the most demanding environments. These doors will not rot, rust, swell, warp or corrode. Designed to meet FDA and cGMP requirements.

100% WATER & CHEMICAL PROOF

Inorganic, closed cell core which does not corrode or absorb moisture. Remains unaffected from exposure to water, steam, disinfectants, chlorine and strong chemicals including H2O2.

ULTIMATE DURABILITY

Extremely strong, lightweight and designed for high usage environments. These doors outperform wood and steel alternatives, bringing you a lifetime of durability and the ultimate cost-effective solution.

UNCOMPROMISING QUALITY

Engineered to offer supreme quality and reliability. We can offer up to a 25 year guarantee on our doorblades.*

FULLY INTEGRATED SYSTEM

Dortek provides complete access solutions which are individually crafted to meet your specification. We offer a choice of colored door panels, frames, hardware, vision panels, access controls, automations and interlocking.

Modular Cleanroom Doors

TECHNICAL FEATURES

DOORLEAF

Seamless fiberglass encapsulating a non-organic, high density polyisocyanurate foam core. Total thickness 1.57" (40mm) or 1.73" (44mm). Moisture absorption zero.

SIZES

Molded in 11 standard widths and four heights. Also available for special order in any non-standard height.

FRAMES

- Available in 2 frame types: SS and Aluminum.
- Modular cleanroom frame options designed for each cleanroom panel supplier. Flush and seamless installation on all cleanroom panels.
- Satin anodised or powder coated white adjustable width aluminium frame, incorporating a neoprene seal for screw fixing to a sub frame.
- Alternative stainless steel frames for fixing to installation panel and blockwork. Doors can be supplied for fixing to clients' own frames.

FINISH

- Easy to clean, maintenance free, smooth, non porous, gelcoat surface with built-in choice of 12 colors.
- Available with antibacterial protection.
- Designed to withstand all typical cleaning methods including hydrogen peroxide.

OPTIONS

- Factory-fitted hardware and door protection.
- Flush vision panels with integral blinds, smart glass or x-ray and laser protection.
- Automations & Interlocking.

GENERAL

- Doors are supplied pre-hung & fully fitted-out for easy site installation.

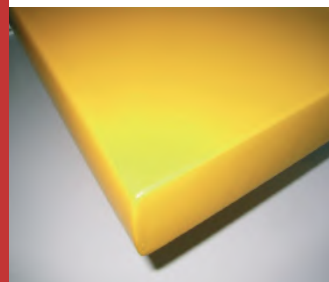
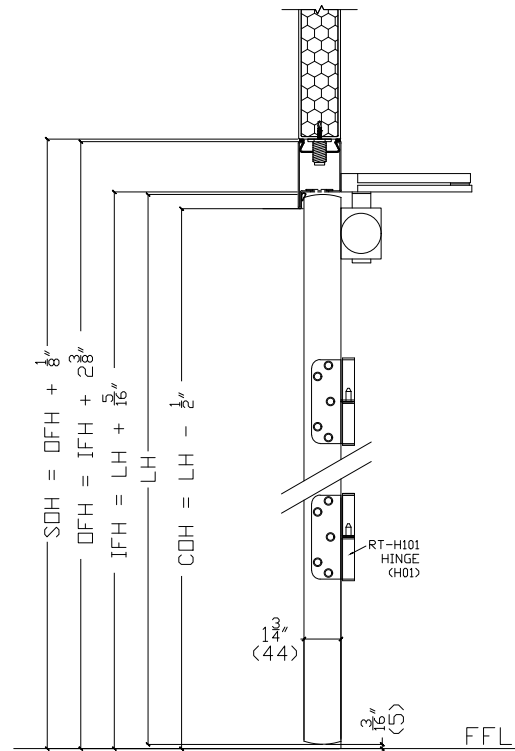
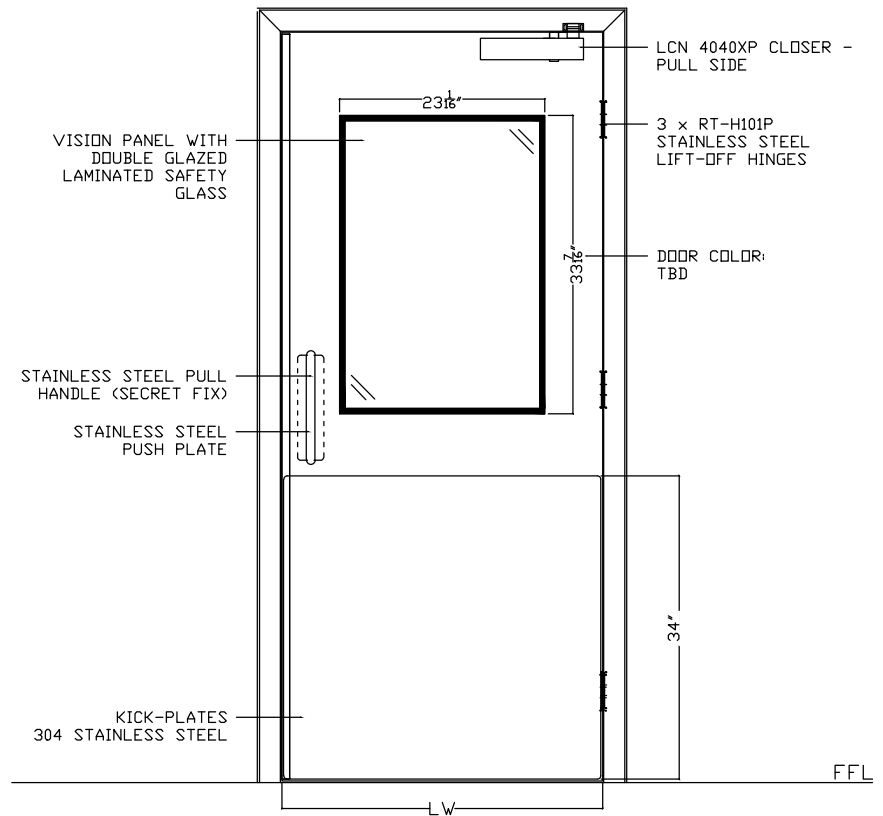

Seamless FRP Door Panel



Optional Flush Vision Panel



Factory-fitted Hardware